



The Patent Office

JB 99/1748

PCT / JB 9 / 1748
28.12.99

INVESTOR IN PEOPLE
09/830096

The Patent Office
Concept House
Cardiff Road
Newport
South Wales
NP10 8QQ

4

PRIORITY DOCUMENT

SUBMITTED OR TRANSMITTED IN COMPLIANCE WITH RULE 17.1(a) OR (b)

REC'D 18 JAN 2000

WIPO PCT

I, the undersigned, being an officer duly authorised in accordance with Section 74(1) and (4) of the Deregulation & Contracting Out Act 1994, to sign and issue certificates on behalf of the Comptroller-General, hereby certify that annexed hereto is a true copy of the documents as originally filed in connection with the patent application identified therein.

I also certify that the attached copy of the request for grant of a Patent (Form 1/77) bears an amendment, effected by this office, following a request by the applicant and agreed to by the Comptroller-General.

In accordance with the Patents (Companies Re-registration) Rules 1982, if a company named in this certificate and any accompanying documents has re-registered under the Companies Act 1980 with the same name as that with which it was registered immediately before re-registration save for the substitution as, or inclusion as, the last part of the name of the words "public limited company" or their equivalents in Welsh, references to the name of the company in this certificate and any accompanying documents shall be treated as references to the name with which it is so re-registered.

In accordance with the rules, the words "public limited company" may be replaced by p.l.c., plc, P.L.C. or PLC.

Re-registration under the Companies Act does not constitute a new legal entity but merely subjects the company to certain additional company law rules.

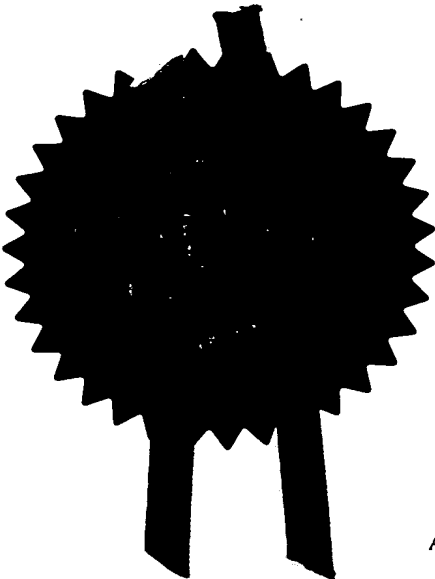

Signed *MRK*

Dated 25 October 1999

This Page Blank (uspto)

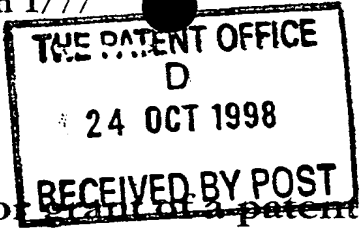

Request for grant of a patent

(See the notes on the back of this form. You can also get an explanatory leaflet from the Patent Office to help you fill in this form)

The Patent Office

Cardiff Road
Newport
Gwent NP9 1RH

1. Your reference PS/BJB/P114GB

2. Patent application number (The Patent Office will fill in this part) **24 OCT 1998** **9823220.0**

3. Full name, address and postcode of the or of each applicant (underline all surnames)
Meritor Light Vehicle Systems - France
8, Rue Sebastien Lehr
88104 Saint-Die
Cedex
France
Patents ADP number (if you know it) 7525967001
If the applicant is a corporate body, give the country/state of its incorporation A French Company

4. Title of the invention An Actuator Assembly

5. Name of your agent (if you have one) WITHERS & ROGERS
"Address for service" in the United Kingdom to which all correspondence should be sent (including the postcode)
~~A Dyer's Buildings~~ Goldings House
Helbom 2 Hays Lane
London LONDON
EC1N 2QP SE1 2HW
Patents ADP number (if you know it) 00 17 66 001

6. If you are declaring priority from one or more earlier patent applications, give the country and the date of filing of the or of each of these earlier applications and (if you know it) the or each application number

Country	Priority application number (if you know it)	Date of filing (day / month / year)
---------	--	-------------------------------------

7. If this application is divided or otherwise derived from an earlier UK application, give the number and the filing date of the earlier application

Number of earlier application	Date of filing (day / month / year)
-------------------------------	-------------------------------------

8. Is a statement of inventorship and of right to grant of a patent required in support of this request? (Answer 'Yes' if:
a) any applicant named in part 3 is not an inventor, or
b) there is an inventor who is not named as an applicant, or
c) any named applicant is a corporate body.
See note (d)) Yes

Patents Form 1/77

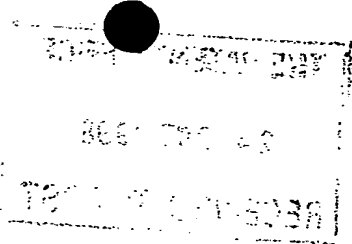

9. Enter the number of sheets for any of the following items you are filing with this form. Do not count copies of the same document

Continuation sheets of this form

Description 4
Claim(s) 3
Abstract
Drawing(s) 3 + 2

10. If you are also filing any of the following, state how many against each item.

Priority documents

Translations of priority documents

Statement of inventorship and right to grant of a patent (Patents Form 7/77)

Request for preliminary examination and search (Patents Form 9/77)

Request for substantive examination (Patents Form 10/77)

Any other documents (please specify)

11. I/We request the grant of a patent on the basis of this application.

Signature W. Acs + Rogers Date 23/10/98
WITHERS & ROGERS

12. Name and daytime telephone number of person to contact in the United Kingdom
Mr John B Jones
0121 233 2997

Warning

After an application for a patent has been filed, the Comptroller of the Patent Office will consider whether publication or communication of the invention should be prohibited or restricted under Section 22 of the Patents Act 1977. You will be informed if it is necessary to prohibit or restrict your invention in this way. Furthermore, if you live in the United Kingdom, Section 23 of the Patents Act 1977 stops you from applying for a patent abroad without first getting written permission from the Patent Office unless an application has been filed at least 6 weeks beforehand in the United Kingdom for a patent for the same invention and either no direction prohibiting publication or communication has been given, or any such direction has been revoked.

Notes

- a) If you need help to fill in this form or you have any questions, please contact the Patent Office on 0645 500505.
- b) Write your answers in capital letters using black ink or you may type them.
- c) If there is not enough space for all the relevant details on any part of this form, please continue on a separate sheet of paper and write "see continuation sheet" in the relevant part(s). Any continuation sheet should be attached to this form.
- d) If you have answered 'Yes' Patents Form 7/77 will need to be filed.
- e) Once you have filled in the form you must remember to sign and date it.
- f) For details of the fee and ways to pay please contact the Patent Office.

AN ACTUATOR ASSEMBLY

The present invention relates to actuator assemblies and in particular electrical actuators used to actuate components, for example door locks, door latches or door deadlocks in vehicles.

It is an object of the present invention to provide a compact actuator assembly. It is a further object to provide an actuator assembly that is easy to install. It is a further object to provide an actuator assembly that has relatively few components and is relatively cheap to produce.

Thus according to the present invention there is provided an actuator assembly including a motor having a body portion and a drive shaft, the drive shaft being drivably connected to a pinion, the pinion drivingly engaging an array of gear teeth of a gear rack the array of gear teeth having a first side adjacent the motor, in which the gear rack is pivotally mounted via a pivot about a pivot axis on said first side of the array of gear teeth.

Preferably the pivot axis passes through the body and/or is proximate that end of the motor remote from the pinion.

Preferably the gear rack includes at least one stop to limit movement of the rack relative to the body portion and preferably the drive shaft passes between the array of gear teeth and a guide portion proximate the gear teeth.

Preferably each stop supports the guide portion.

According to a further aspect of the invention there is provided an actuator assembly including a motor having a body portion and a drive shaft, the drive shaft being drivably connected to a pinion, the pinion drivingly engaging an array of gear teeth of a gear rack with the gear rack being mounted for movement on the body portion.

Preferably the motor is an electric motor.

The invention will now be described by way of example only with reference to the drawings in which;-

Figures 1,2 and 3 are different isometric views of an actuator assembly according to the present invention.

With reference to figures 1-3 there is shown an actuator assembly 10 which includes a motor 12 (in this case an electric motor). The motor includes a body portion 14 and a drive shaft 16. The drive shaft is drivably connected to a pinion 18. The pinion 18 drivingly engages an array of gear teeth 20 fixed to a gear rack 22.

The gear rack is of generally octant shape with the array of gear teeth 20 being arranged in an arcuate manner. The array of gear teeth have a first side 21 adjacent the motor. The gear rack includes a boss 24 which fits into a hole (not shown) of a housing (not shown) to provide a pivot. Gear rack 22 thus can rotate about axis 25A of boss 24. It should be noted that axis 25A passes through body portion 14.

The housing substantially surrounds the motor and gear rack and can be substantially sealed against the ingress of contaminants eg. dirt, dust, or water. The motor is secured in the housing, preferably by engagement of each end of the drive shaft with the housing.

Preferably the housing is of at least two part form, a first part having two cut-outs each cut-out accepting and supporting one end of the drive shaft, the second part having complementary cut-outs which in conjunction with the cut-outs of the first part provide a journal bearing for each end of the drive shaft 16. The second part also has a hole to accept and provide a journal for boss 24.

In use the boss is connected to a lever situated on the outside of the housing, the lever being connected to the component to be actuated.

Extending beyond the gear teeth 20 there are two stops 26 and 28 which limit movement of the gear rack relative to the body portion 14 by engagement with the drive shaft 16. Figure 1 shows the gear rack 22 at an extreme position wherein stop 28 has engaged drive shaft 16. Figure 1 also shows (in chain dotted line) the other extreme of movement of the gear rack relative to the body portion wherein stop 26 has engaged drive shaft 16.

Guide portion 30 connects stops 26 and 28, resulting in a stronger arrangement. Guide portion 30 is mounted on the opposite side of shaft 16 to the array of gear teeth 20. Guide portion 30 includes a guide surface 32 along which the drive shaft 16 passes in close proximity or alternatively in light engagement therewith. When the motor 12 is producing torque the engagement of the pinion with appropriate gear teeth of the array causes a separating force which preferably can be counteracted by the guide surface 32

acting upon the drive shaft 16, thus reducing the load as seen by the pivot 25.

In use operation of the motor in a first rotational direction causes the pinion to move the gear rack to a first position and operation of the motor in a second rotational direction causes the pinion to move the gear rack to a second position.

In further embodiments the gear rack can be of an alternative segment shape such as a quadrant or a sextant and in yet further embodiments the gear rack need not be of a segment shape.

The invention provides for a particularly compact arrangement since a substantial part of the gear rack can be arranged to lie alongside the motor. Furthermore the actuator assembly is axially compact, it being noted that no part of the gear rack projects beyond that end of the drive shaft having the pinion secured thereto. It should also be noted that the actuator shown in the figures only has two moving parts namely the drive shaft/pinion and the gear rack.

CLAIMS

1. An actuator assembly including a motor having a body portion and a drive shaft, the drive shaft being drivably connected to a pinion, the pinion drivingly engaging an array of gear teeth of a gear rack the array of gear teeth having a first side adjacent the motor, in which the gear rack is pivotally mounted via a pivot about a pivot axis on said first side of the array of gear teeth.
2. An actuator assembly as defined in Claim 1 in which the pivot axis passes through the body portion.
3. An actuator assembly as defined in Claim 1 or 2 in which the pivot axis is proximate that end of the motor remote from the pinion.
4. An actuator assembly as defined in any preceding claim in which the gear rack includes at least one stop to limit movement of the rack relative to the body portion.
5. An actuator assembly as defined in Claim 4 in which the or each stop engages the drive shaft.
6. An actuator assembly as defined in Claim 5 in which the or each stop engages a portion of the drive shaft on the side of the pinion remote from the motor.
7. An actuator assembly as defined in any preceding claim in which the drive shaft passes between the array of gear teeth and a guide portion proximate the gear teeth.

8. An actuator assembly as defined in Claim 7 when dependent on any one of Claim 4-6 in which the guide portion is supported by the or each stop.

9. An actuator assembly as defined in any preceding claim which further includes a housing in which the motor is secured.

10. An actuator assembly as defined in Claim 9 in which the pivot is mounted on the housing.

11. An actuator assembly as defined in Claim 9 or 10 in which the pivot includes a boss of the gear rack to which in use a lever is attached.

12. An actuator assembly as defined in Claim 11 in which the boss at least partially projects through the housing.

13. An actuator assembly as defined in any one of Claims 9-12 in which the drive shaft engages the housing.

14. An actuator assembly as defined in any one of Claims 9-13 in which the housing is substantially sealed.

15. An actuator assembly as defined in any one of Claims 9-14 in which the housing has at least a first and second part, the parts having co-operating cut-outs to provide for at least one end of the drive shaft.

16. An actuator assembly as defined in any one of Claims 1-9 or 11-15 when dependent upon Claim 9 in which the pivot is mounted on the body portion.

17. An actuator assembly including a motor having a body portion and a drive shaft, the drive shaft being drivably connected to a pinion, the pinion drivingly engaging an array of gear teeth of a gear rack with the gear rack being mounted for movement on the body portion.

18. An actuator assembly as defined in any preceding claim in which the motor is an electric motor.

19. An actuator assembly as herein before described with reference to or as shown in figures 1-3 of the accompanying drawings.

This Page Blank (user)

1/3

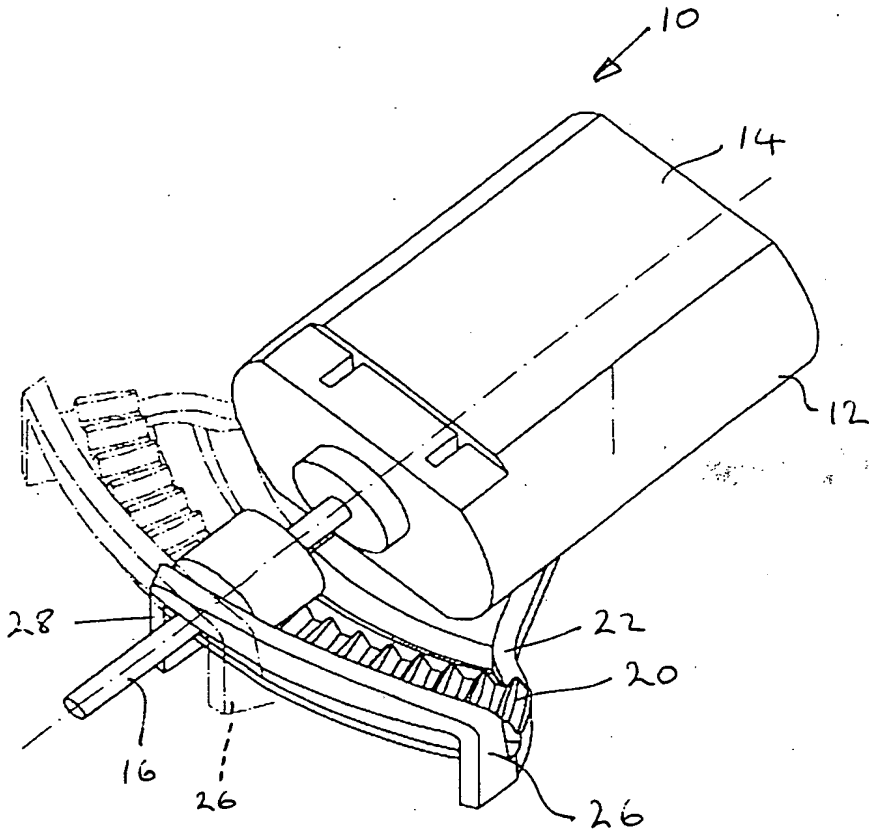
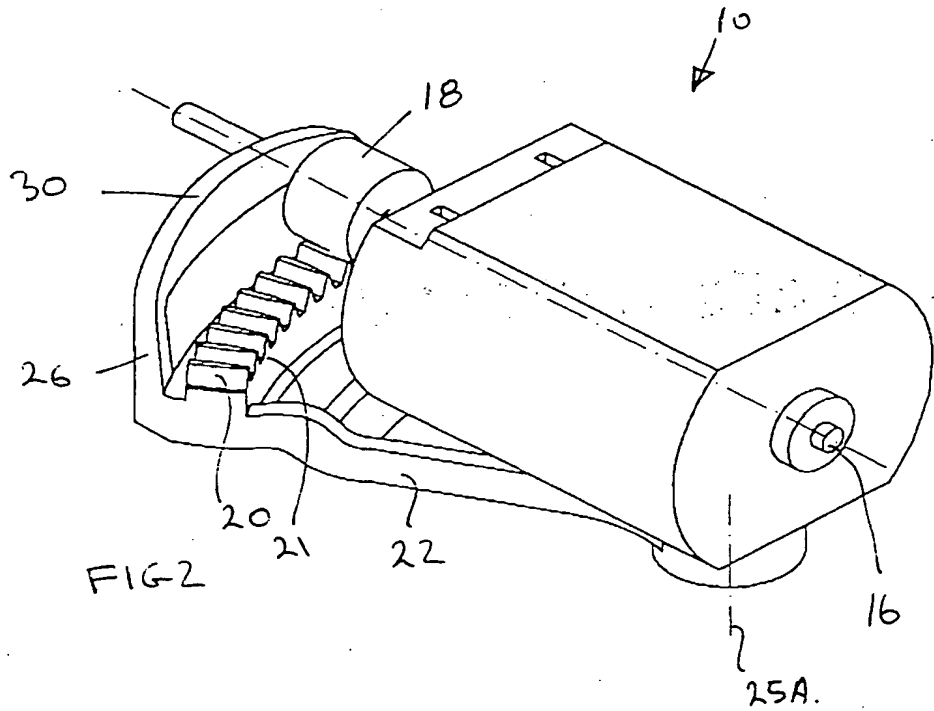

FIG 1

This Page Blank (uspto)

2/3



This Page Blank (uspto)

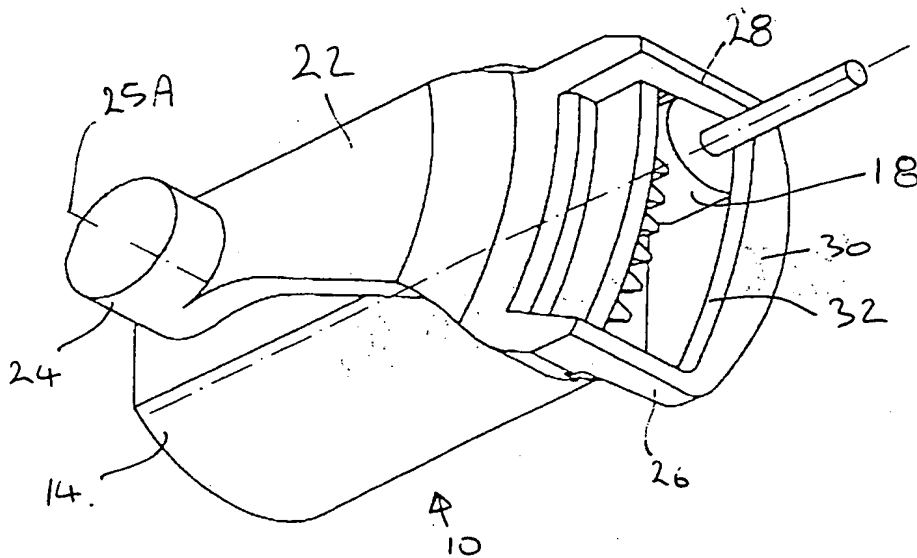

FIG 3

This Page Blank (uspto)